



MIAMI-DADE COUNTY
BUILDING AND NEIGHBORHOOD COMPLIANCE DEPARTMENT (BNC)
BOARD AND CODE ADMINISTRATION DIVISION

MIAMI-DADE COUNTY
PRODUCT CONTROL SECTION
 11805 SW 26 Street, Room 208
 Miami, Florida 33175-2474
 T (786) 315-2590 F (786) 315-2599

www.miamidade.gov/building

NOTICE OF ACCEPTANCE (NOA)

Town & Country Industries, Inc.
400 West McNab Road
Ft. Lauderdale, Florida 33309

SCOPE:

This NOA is being issued under the applicable rules and regulations governing the use of construction materials. The documentation submitted has been reviewed and accepted by Miami-Dade County BNC-Product Control Section to be used in Miami Dade County and other areas where allowed by the Authority Having Jurisdiction (AHJ).

This NOA shall not be valid after the expiration date stated below. The Miami-Dade County Product Control Section (In Miami Dade County) and/or the AHJ (in areas other than Miami Dade County) reserve the right to have this product or material tested for quality assurance purposes. If this product or material fails to perform in the accepted manner, the manufacturer will incur the expense of such testing and the AHJ may immediately revoke, modify, or suspend the use of such product or material within their jurisdiction. BNC reserves the right to revoke this acceptance, if it is determined by Miami-Dade County Product Control Section that this product or material fails to meet the requirements of the applicable building code.

This product is approved as described herein, and has been designed to comply with the High Velocity Hurricane Zone of the Florida Building Code.

DESCRIPTION: 0.0615" (min.) Aluminum Storm Panels Shutter

APPROVAL DOCUMENT: Drawing No. 08-352, titled "0.0615" Aluminum Storm Panel", sheets 1 through 6 of 6, prepared by Knezevich Associates Consulting Engineers, dated September 01, 2008, signed and sealed by V.J. Knezevich, P.E., on September 03, 2008 bearing the Miami-Dade County Product Control Renewal stamp with the Notice of Acceptance number and the expiration date by the Miami-Dade County Product Control Section.

MISSILE IMPACT RATING: Large and Small Missile Impact Resistant

LABELING: Each panel shall bear a permanent label with the manufacturer's name or logo, city, state, the following statement: "Miami-Dade County Product Control Approved", and NOA number, per TAS-201, TAS-202, and TAS-203, unless otherwise noted herein.

RENEWAL of this NOA shall be considered after a renewal application has been filed and there has been no change in the applicable building code negatively affecting the performance of this product.

TERMINATION of this NOA will occur after the expiration date or if there has been a revision or change in the materials, use, and/or manufacture of the product or process. Misuse of this NOA as an endorsement of any product, for sales, advertising or any other purposes shall automatically terminate this NOA. Failure to comply with any section of this NOA shall be cause for termination and removal of NOA.

ADVERTISEMENT: The NOA number preceded by the words Miami-Dade County, Florida, and followed by the expiration date may be displayed in advertising literature. If any portion of the NOA is displayed, then it shall be done in its entirety.

INSPECTION: A copy of this entire NOA shall be provided to the user by the manufacturer or its distributors and shall be available for inspection at the job site at the request of the Building Official.

This NOA **renews NOA # 09-0114.04** and consists of this page 1, evidence submitted pages E-1, E-2, and E-3 as well as approval document mentioned above.

The submitted documentation was reviewed by **Helmy A. Makar, P.E., M.S.**



Helmy A. Makar
 06/09/2011

NOA No. 11-0428.04
Expiration Date: 07/19/2016
Approval Date: 06/09/2011
 Page 1

NOTICE OF ACCEPTANCE: EVIDENCE SUBMITTED

1. EVIDENCE SUBMITTED UNDER PREVIOUS APPROVAL #00-1212.05

A. DRAWINGS

1. *Drawing no. 00-205, titled " 0.0615" Aluminum Storm Pane ", prepared by Knezevich & Associates, Inc., dated December 8, 2000, last revision #1 dated May 24, 2001, sheets 1 through 6 of 6, signed and sealed by V. J. Knezevich, P.E.*

B. TESTS

1. *Test report on Large Missile Impact Test, Uniform Static Air Pressure Test and Cyclic Wind Pressure Test of 0.0615" aluminum storm panels, prepared by Construction Testing Corporation, Report No. CTC-00-038, dated November 7, 2000, signed and sealed by Yamil G. Kuri, P.E.*
2. *Letter from Construction Testing Corporation, for test report No. CTC-00-038, dated June 1, 2001, for the panel thickness, signed and sealed by George Dotzler.*

C. CALCULATIONS

1. *Comparative analysis and Anchor Analysis, dated December 8, 2000, pages 1 through 52, prepared by Knezevich and Associates, Inc., signed and sealed by V. J. Knezevich, P.E.*
2. *Revised Comparative analysis and Anchor Analysis, dated June 20, 2001, pages 1 through 4, prepared by Knezevich and Associates, Inc., signed and sealed by V. J. Knezevich, P.E.*

D. MATERIAL CERTIFICATIONS

1. *Mill Certified Inspection Report of coils, not dated, for Aluminum Alloy 3004-H34 by Jupiter Aluminum Corp., with chemical composition and physical properties.*
2. *Tensile Test Report from Certified Testing Laboratories, Test Report # CTL – 799F dated August 28, 2000, for Aluminum sample #00-038, tested per ASTM E8-93, signed and sealed by Ramesh Patel, P.E.*

2. EVIDENCE SUBMITTED UNDER PREVIOUS APPROVAL # 03-0421.12

A. DRAWINGS

1. *Drawing No. 03-260, titled " 0.0615" Aluminum Storm Panel ", sheets 1 through 6 of 6, prepared by Knezevich & Associates, Inc., dated April 04, 2003, last revision #1 dated September 23, 2003 signed and sealed by V.J. Knezevich, P.E.*

B. TESTS

1. *None.*

C. CALCULATIONS

1. *None.*

D. QUALITY ASSOURANCE

1. *By Miami-Dade County Building Code Compliance Office.*

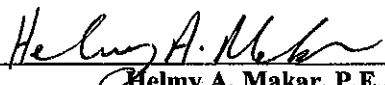

Helmy A. Makar, P.E., M.S.
BNC, Product Control Unit Supervisor
NOA No. 11-0428.04
Expiration Date: 07/19/2016
Approval Date: 06/09/2011

Town & Country Industries, Inc.

NOTICE OF ACCEPTANCE: EVIDENCE SUBMITTED

E. MATERIAL CERTIFICATIONS

1. *None.*

3. EVIDENCE SUBMITTED UNDER PREVIOUS APPROVAL # 05-0713.02

A. DRAWINGS

1. *Drawing No. 05-354, titled " 0.0615" Aluminum Storm Panel ", sheets 1 through 6 of 6, prepared by Thornton-Tomasetti Group, dated June 29, 2005, last revision #0 dated June 29, 2005 signed and sealed by V.J. Knezevich, P.E.*

B. TESTS

1. *None.*

C. CALCULATIONS

1. *Anchor Analysis, dated June 15, 2005, 31 pages, prepared by Thornton-Tomasetti Group, signed and sealed by V. J. Knezevich, P.E.*

D. QUALITY ASSOURANCE

1. *By Miami-Dade County Building Code Compliance Office.*

E. MATERIAL CERTIFICATIONS

1. *None.*

4. EVIDENCE SUBMITTED UNDER PREVIOUS APPROVAL #09-0114.04

A. DRAWINGS

1. *Drawing No. 08-352, titled " 0.0615" Aluminum Storm Panel ", sheets 1 through 6 of 6, prepared by Knezevich Associates Consulting Engineers, dated September 01, 2008, signed and sealed by V.J. Knezevich, P.E., on September 03, 2008.*

B. TESTS

1. *None.*

C. CALCULATIONS

1. *Anchor Analysis, dated September 09, 2008, 19 pages, prepared by Knezevich Associates Consulting Engineers, dated September 01, 2008, signed and sealed by V.J. Knezevich, P.E., on September 03, 2008.*

D. QUALITY ASSOURANCE

1. *By Miami-Dade County Building Code Compliance Office.*

E. MATERIAL CERTIFICATIONS

1. *None.*

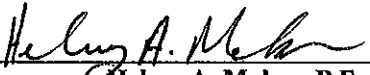

Helmy A. Makar, P.E., M.S.
BNC, Product Control Unit Supervisor
NOA No. 11-0428.04
Expiration Date: 07/19/2016
Approval Date: 06/09/2011

NOTICE OF ACCEPTANCE: EVIDENCE SUBMITTED

5. NEW EVIDENCE SUBMITTED

A. DRAWINGS

1. *None.*

B. TESTS

1. *Test report on Large Missile Impact Test and Cyclic Wind Pressure Test of 0.0615" aluminum storm panels, prepared by Hurricane Test Laboratory, LLC, Report No. 0353-0308-11, dated April 07, 2011, signed and sealed by Vinu J. Abraham, P.E.*

C. CALCULATIONS

1. *None.*

D. QUALITY ASSOURANCE

1. *By Miami-Dade County Building and Neighborhood Compliance Department (BNC).*

E. MATERIAL CERTIFICATIONS

1. *None.*

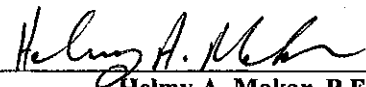

Helmy A. Makar, P.E., M.S.
BNC, Product Control Unit Supervisor
NOA No. 11-0428.04
Expiration Date: 07/19/2016
Approval Date: 06/09/2011

0.0615" ALUMINUM STORM PANEL

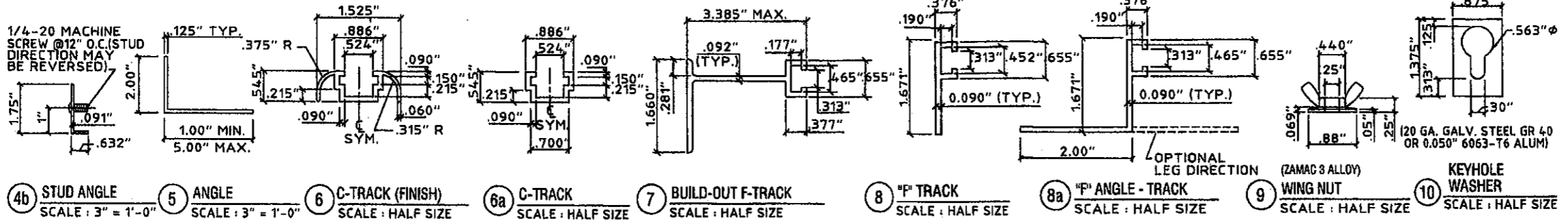
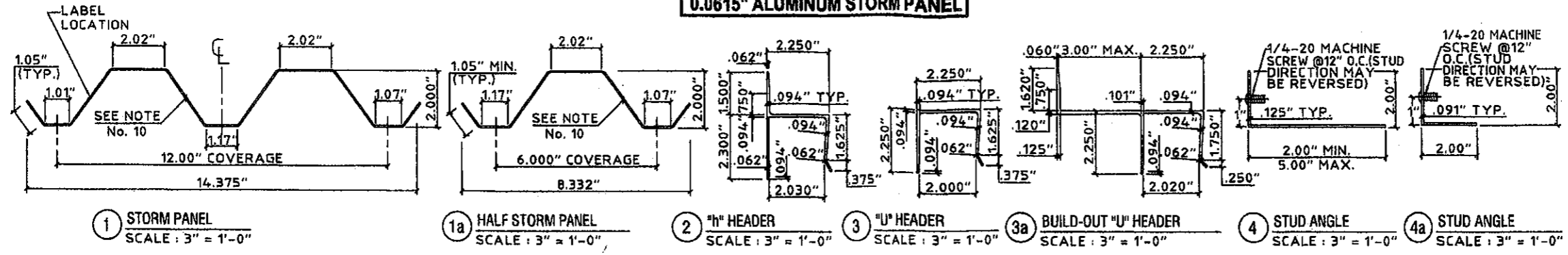

- GENERAL NOTES:**
- THESE APPROVAL DOCUMENTS REPRESENT A SHUTTER SYSTEM ANALYZED WITH THE PROVISION SET FOR THE ISSUANCE OF A NOTICE OF ACCEPTANCE (NOA) BY MIAMI-DADE COUNTY PRODUCT CONTROL DIVISION FOR THE HIGH VELOCITY HURRICANE ZONE (HVHZ) OF THE FLORIDA BUILDING CODE.
 - NO INCREASE IN ALLOWABLE STRESS HAS BEEN USED IN THE DESIGN OF THIS PRODUCT. WIND LOAD DURATION FACTOR Cd = 1.6 WAS USED FOR WOOD LAG SCREW DESIGN.
 - DETERMINE THE POSITIVE AND NEGATIVE DESIGN LOADS TO USE WHEN REFERENCING THESE DOCUMENTS IN ACCORDANCE WITH THE GOVERNING CODE AND GOVERNING WIND VELOCITY.
 - THESE APPROVAL DOCUMENTS ARE GENERIC AND DO NOT INCLUDE INFORMATION FOR SITE-SPECIFIC APPLICATION OF THIS SHUTTER SYSTEM.
 - USE OF THESE APPROVAL DOCUMENTS SHALL COMPLY WITH CHAPTER 61G15-23 OF THE FLORIDA ADMINISTRATIVE CODE.
 - THESE APPROVAL DOCUMENTS ARE SUITABLE TO BE APPLIED BY THE CONTRACTOR PROVIDED THE CONTRACTOR DOES NOT DEVIATE FROM THE CONDITIONS DETAILED HEREIN AND THE CONTRACTOR VERIFIES THAT THE EXISTING STRUCTURE DOES NOT DEVIATE IN EITHER FORM OR MATERIAL FROM THE STRUCTURAL SUBSTRATES DETAILED HEREIN.
 - ANY MODIFICATIONS OR ADDITIONS TO THESE APPROVAL DOCUMENTS WILL VOID THE APPROVAL DOCUMENTS.
 - WHEN THE SITE CONDITIONS DEVIATE FROM THESE APPROVAL DOCUMENTS, THE BUILDING OFFICIAL MAY ELECT ONE OF THE FOLLOWING OPTIONS:
 - REQUIRE THAT SITE SPECIFIC DOCUMENTS BE PREPARED, SIGNED, DATED AND SEALED BY A LICENSED ENGINEER OR REGISTERED ARCHITECT, WHICH DETAIL AND JUSTIFY THE DEVIATION. SAID DOCUMENTS SHALL BE SUBMITTED TO THE PRODUCT ENGINEER FOR REVIEW AS A CONDITION TO THE BUILDING OFFICIAL GRANTING HIS/HER APPROVAL.
 - REQUIRE THAT A ONE-TIME SITE SPECIFIC APPROVAL BE APPLIED FOR AND SECURED FROM THE MIAMI-DADE COUNTY PRODUCT CONTROL DIVISION.
 - WHEN THE SITE CONDITION DEVIATIONS OCCUR WITHIN THE HIGH VELOCITY HURRICANE ZONE AREAS ONLY OPTION "B" SHALL BE ACCEPTED BY THE BUILDING OFFICIAL.
 - PRODUCT MARKINGS SHALL BE WITHIN 12" OF ONE END OF THE PANEL WITH A MINIMUM OF ONE MARKING PER PANEL AND SHALL BE PERMANENTLY LABELED AS FOLLOWS:

TOWN & COUNTRY INDUSTRIES,
FT. LAUDERDALE, FL
MIAMI-DADE COUNTY PRODUCT APPROVED
 - STORM PANELS SHALL BE 3004-H34 OR 5052-H34 ALUMINUM ALLOY, WITH THE FOLLOWING MINIMUM THICKNESS AND MECHANICAL PROPERTIES: NOMINAL 0.0615"
 - ALL EXTRUSIONS SHALL BE 6063-T6 ALUMINUM ALLOY, U.O.N.
 - ALL BOLTS AND WASHERS SHALL BE GALVANIZED OR STAINLESS STEEL WITH A MINIMUM TENSILE STRENGTH OF 60 K.S.I., U.O.N.
 - TOP & BOTTOM DETAILS SHOWN MAY BE INTERCHANGED AS FIELD CONDITIONS DICTATE. PANELS MAY BE MOUNTED HORIZONTALLY WHERE APPLICABLE, EXCEPT FOR "h" AND "u" HEADER MOUNTING CONDITIONS.

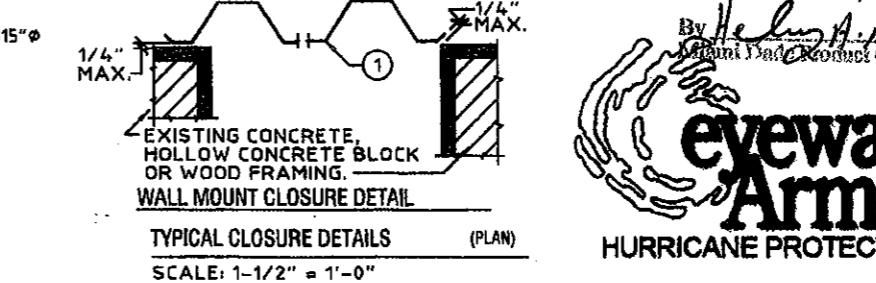
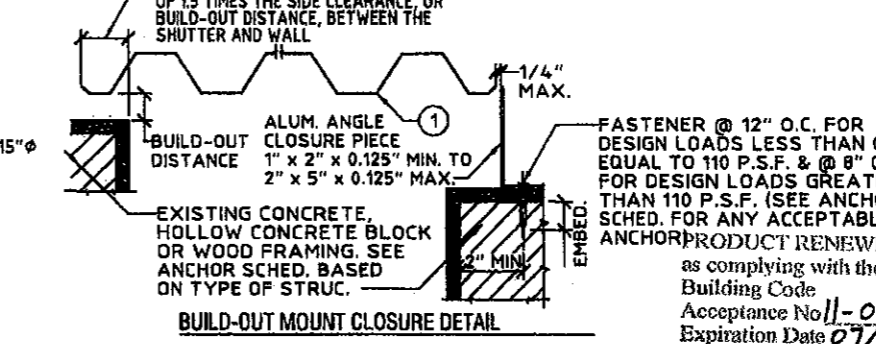
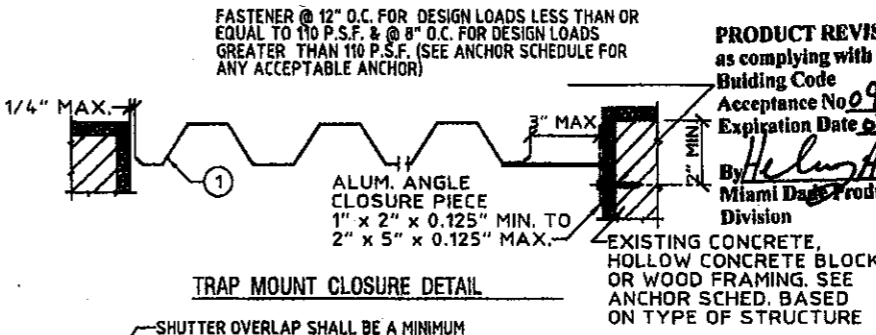
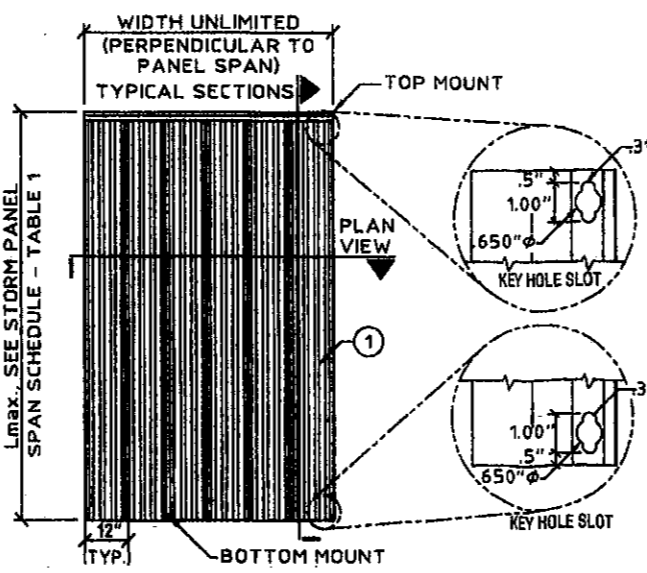
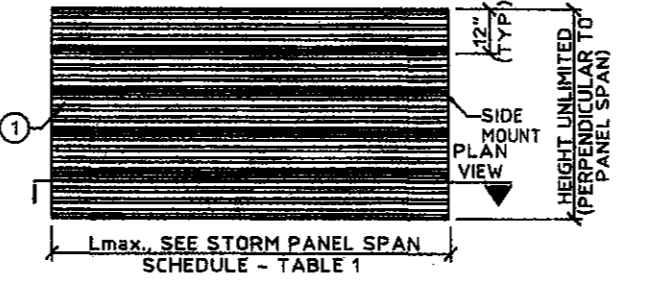

PRODUCT REVISED
as complying with the Florida Building Code
Acceptance No. 09-0114.04
Expiration Date 07/19/2011
By *Helmut A. Mark*
Miami Dade Product Control Division

as complying with the Florida Building Code
Acceptance No. 11-0428.04
Expiration Date 07/19/2016
By *Helmut A. Mark*
Miami Dade Product Control

KNEZEVICH ASSOCIATES
Consulting Engineers
2590 S.W. 105th Terrace
Davie, Florida 33324
(954) 881-8933 • F (954) 452-7990 • COA 27988
www.knezevich.com email: vk@knezevich.com

Copyright © 2008 Knezevich & Associates, LLC 0/0/0 Knezevich Associates

Town & Country
INDUSTRIES
Wholesale Aluminum and Building Products

400 WEST MEVUS ROAD
DAVIE, FL 33309
PHONE 954.970.9999 FAX 954.970.9988

revisions	description

V.J. Knezevich
Professional Engineer
FL License No. 75 0016083
FLORIDA CONTRACTOR 27989

Sept 3, 2008

drawn by: scale
wbs / AS NOTED

date: 09/01/2008

project no.
08-352

PAGE 1 of 6

0.0615" ALUMINUM STORM PANEL

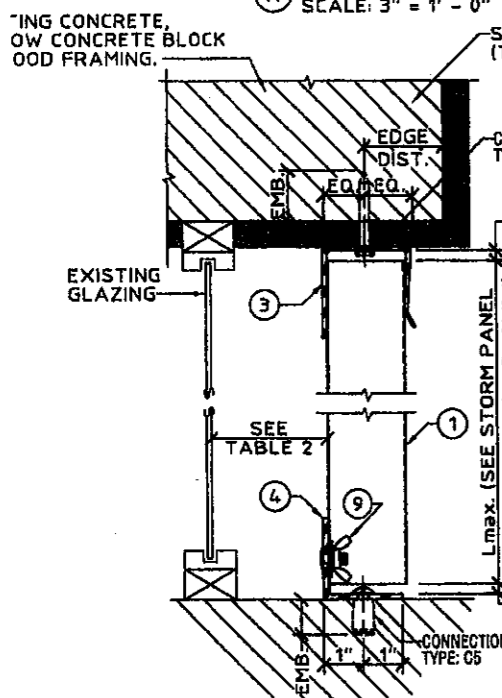
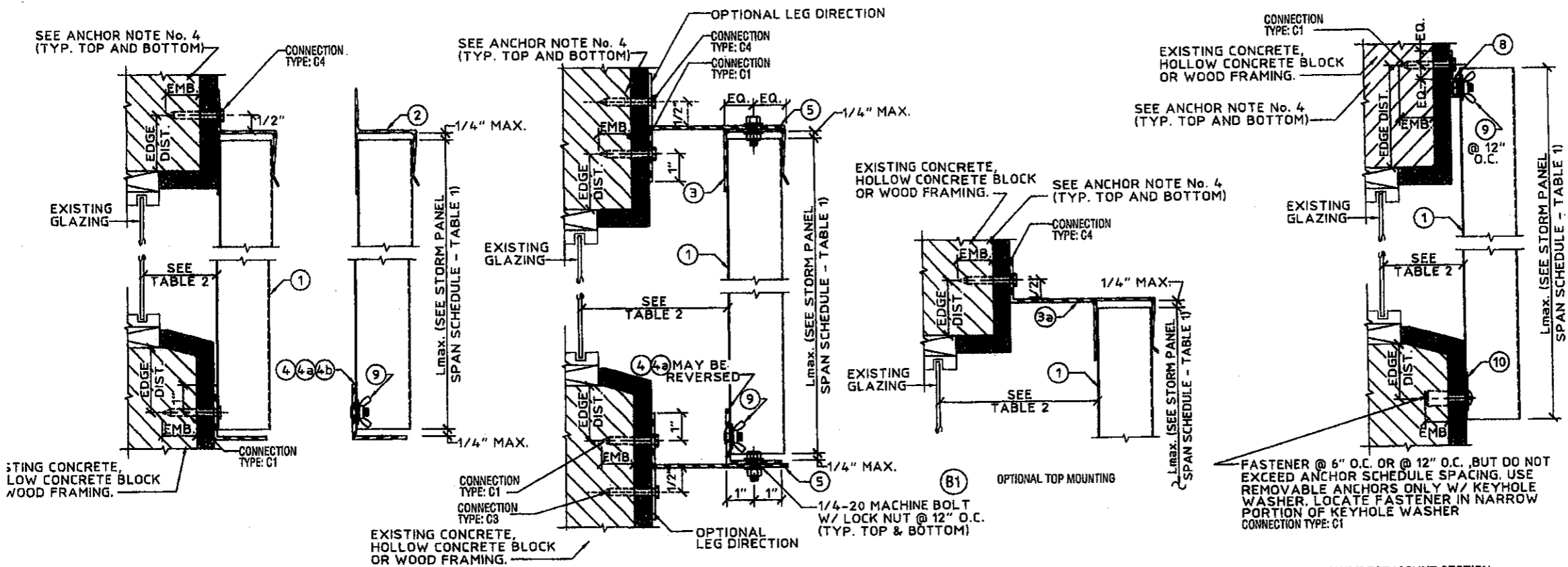

DETAIL (E) ("PASS THRU" SEC.) ANCHOR SCHEDULE

1/4" Ø JTW TAPCON W/ 1-3/4" MIN. (CONC.) OR 1-1/4" MIN. (BLOCK) EMBEDMENT		1/4" Ø POWERS CALK-IN W/ 7/8" EMBEDMENT & 1/4"-20 STAINLESS STEEL MACHINE SCREW	1/4" Ø x MIN. 2-1/2" LONG WOOD LAG SCREW W/ MINIMUM 1-3/4" EMBEDMENT SHEAR PARALLEL OR PERPENDICULAR TO WOOD GRAIN
CONC. (3.02 KSI)	0-90 BLOCK CONC.	CONC. (2.00 KSI)	WOOD
12"	4"	7"	12"

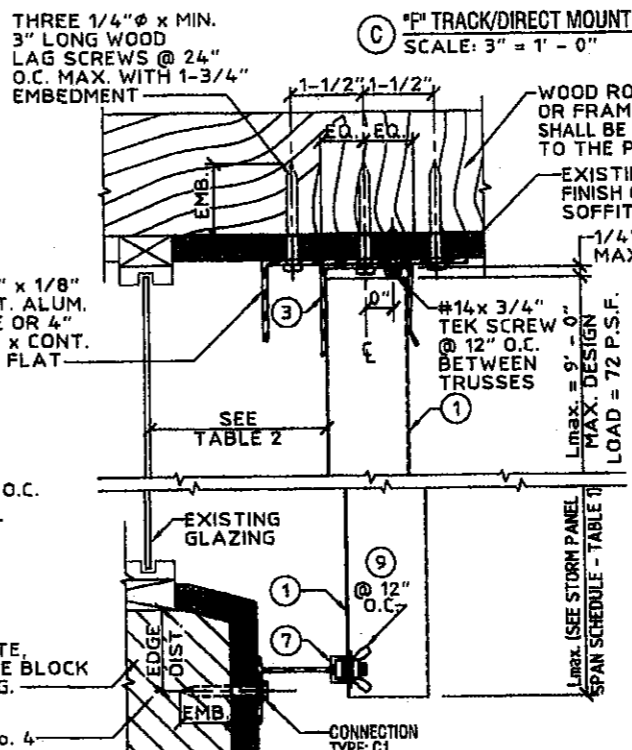
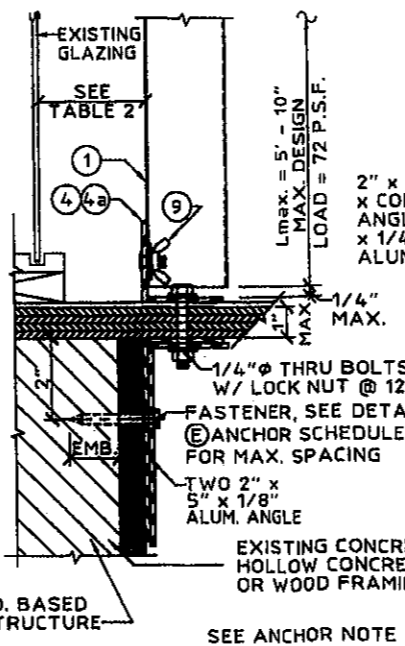

PRODUCT REVISED
as complying with the Florida Building Code
Acceptance No. **09-0114.04**
Expiration Date **07/19/2011**
By *Helmut A. Mahr*
Miami Dade Product Control Division

PRODUCT RENEWED
as complying with the Florida Building Code
Acceptance No. **11-0428.04**
Expiration Date **07/19/2016**
By *Helmut A. Mahr*
Miami Dade Product Control Division



KNEZEVICH ASSOCIATES
Consulting Engineers
2560 S.W. 105th Terrace • Dania, Florida 33324
(954) 821-8833 • F. (954) 452-7950 • OIA 27888
website: www.knezevich.com email: info@knezevich.com

Copyright © 2008 Knezevich & Associates, LLC d/b/a Knezevich Associates

Town & Country INDUSTRIES
Wholesale Aluminum and Building Products

140 WEST MCNEIL ROAD
FORT LAUDERDALE, FL 33309
PHONE 954.970.9999 FAX 954.970.9988

revisions	description	date	by

V.J. Knezevich
Professional Engineer
FL License No. PE 0010983
FLORIDA OIA No.: 27888

Helmut A. Mahr
Sept 3, 2008
drawn by *WBS* scale AS NOTED
date 09/01/2008
project no. **08-352**

0.0615" ALUMINUM STORM PANEL

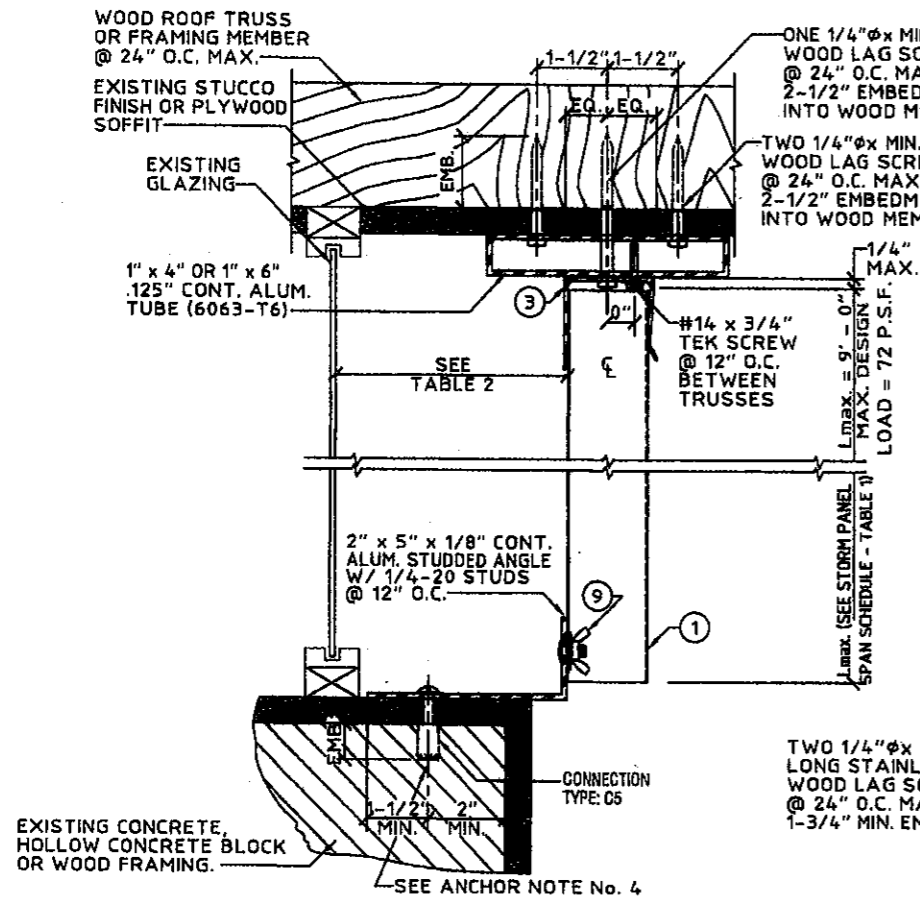

G BUILD-DOWN / BUILD-OUT SECTION
SCALE: 3" = 1' - 0"

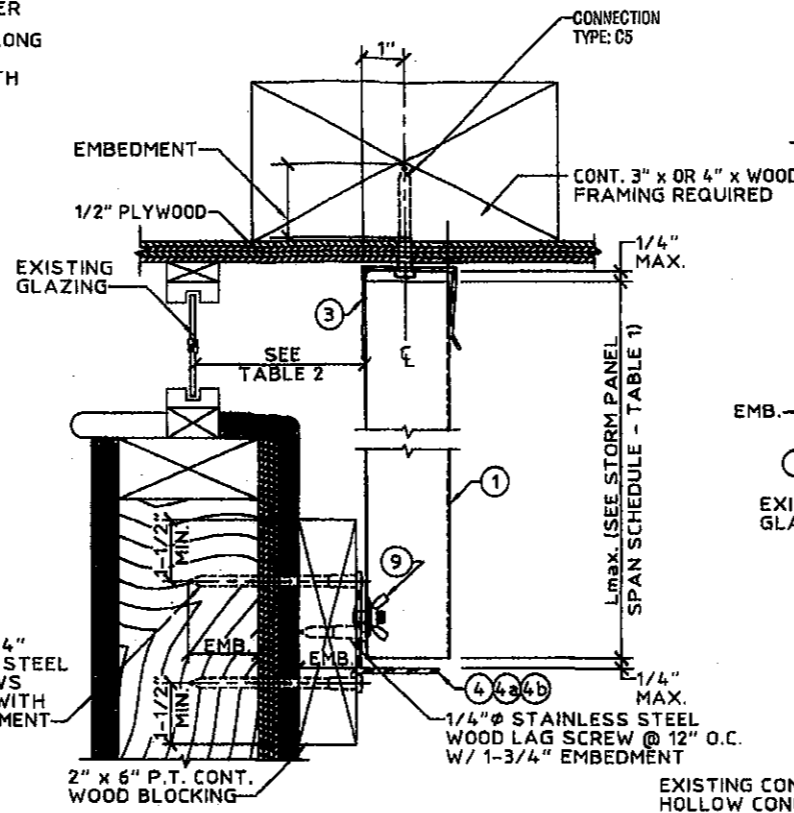

H CEILING/BUILD-OUT MOUNT SECTION
SCALE: 3" = 1' - 0"

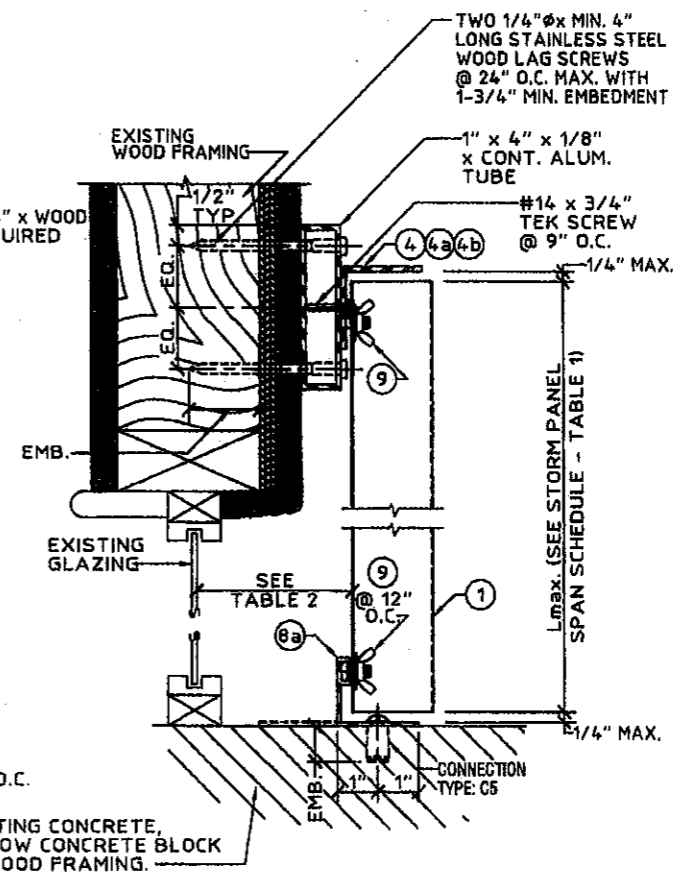

J BUILD-OUT/FLOOR MOUNT SECTION
SCALE: 3" = 1' - 0"

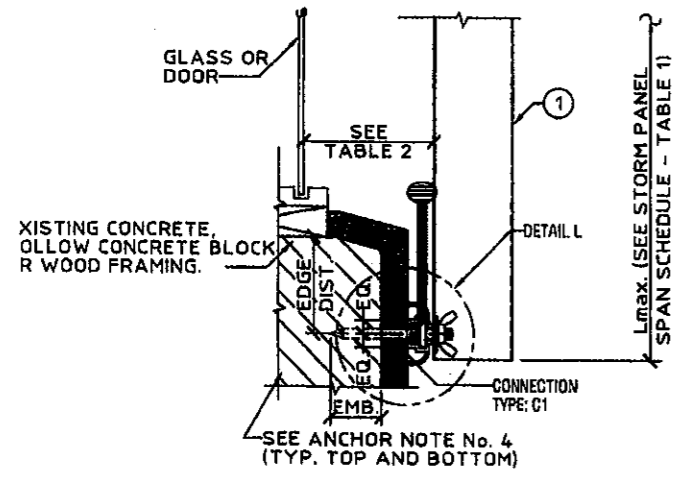

K C-TRACK ASSEMBLY - INSIDE MOUNT
SCALE: 3" = 1' - 0"

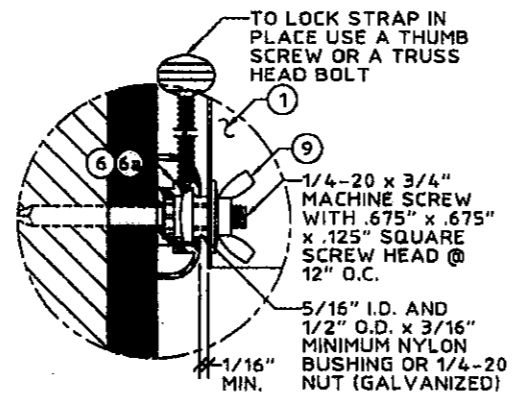

L C-TRACK ASSEMBLY - (BLOW UP)
SCALE: HALF SIZE

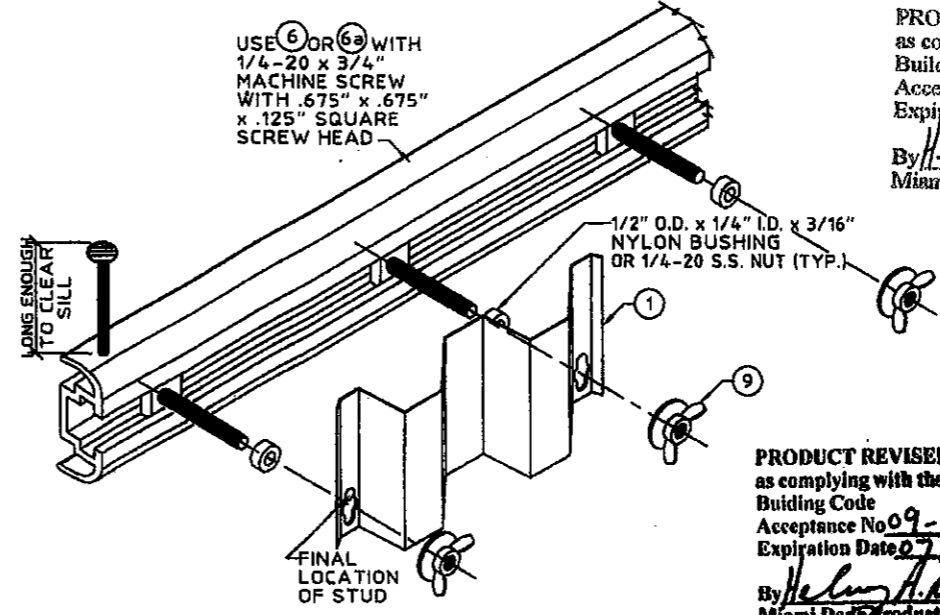

M C-TRACK ASSEMBLY (ISOMETRIC VIEW)
N.T.S.

PRODUCT RENEWED
as complying with the Florida
Building Code
Acceptance No **11-0428.04**
Expiration Date **07/19/2016**
By *Helmut A. Miller*
Miami Dade Product Control

PRODUCT REVISED
as complying with the Florida
Building Code
Acceptance No **09-0114.04**
Expiration Date **07/19/2011**
By *Helmut A. Miller*
Miami Dade Product Control
Division



KNEZEVICH ASSOCIATES
Consulting Engineers
2590 S.W. 105th Terrace, Davie, Florida 33324 27989
(954) 827-8933 F. (954) 422-7930
website: www.knezevich.com email: info@knezevich.com

Town & Country
Wholesale Aluminum and Building Products
600 WEST MCNAB ROAD
FORT LAUDERDALE, FL 33309
PHONE 954.970.9999 FAX 954.970-9988

no.	date	by	description

V.J. Knezevich
Professional Engineer
FL License No: PE 0010663
FLORIDA OSHA No. 27989

[Signature]
Sept 3, 2008

drawn by: *[Signature]*
check by: *[Signature]*
notes: AS NOTED

date: 09/01/2008
project no: **08-352**

PAGE 3 of 6

0.0615" ALUMINUM STORM PANEL

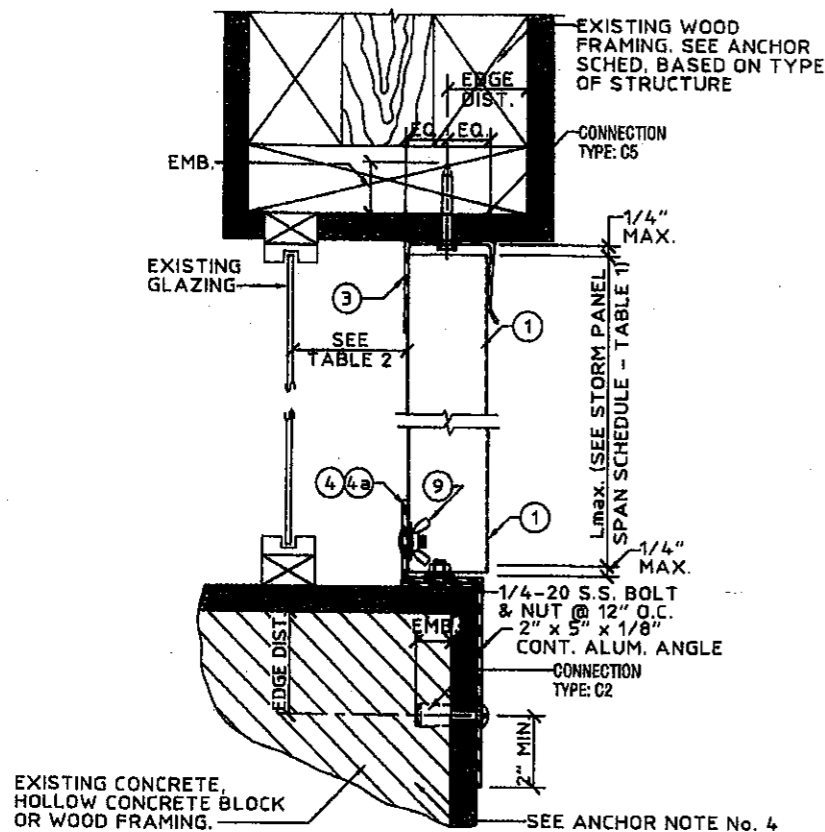

(N) WOOD CEILING/ INSIDE MOUNT SECTION
SCALE: 3" = 1'-0"

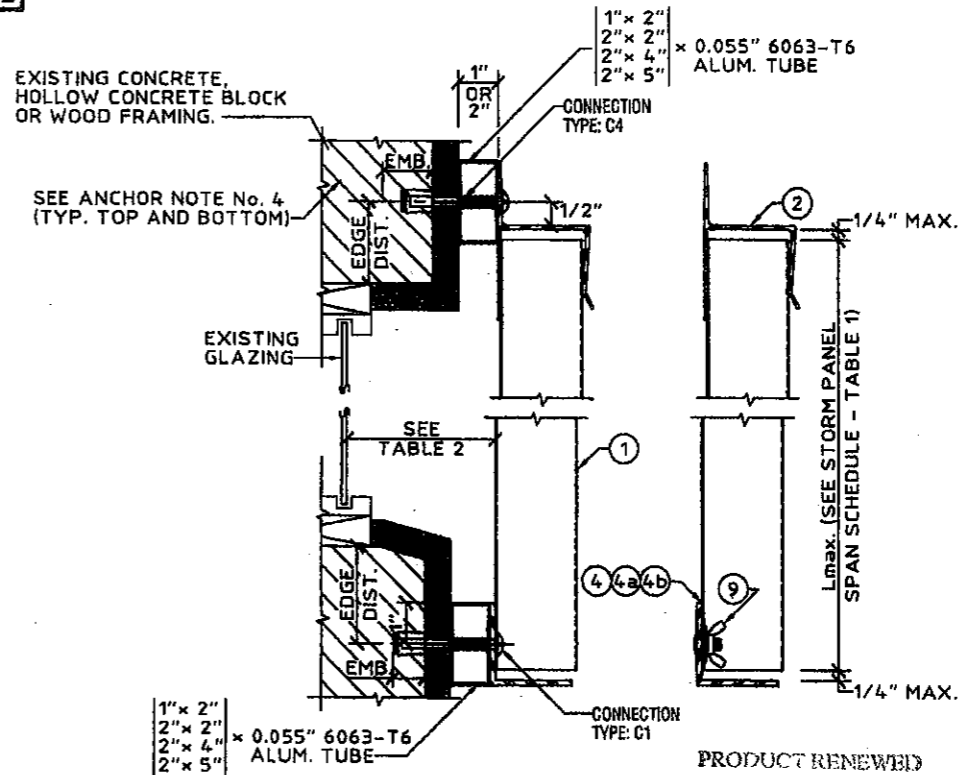

(P) WALL MOUNT SECTION
SCALE: 3" = 1'-0"

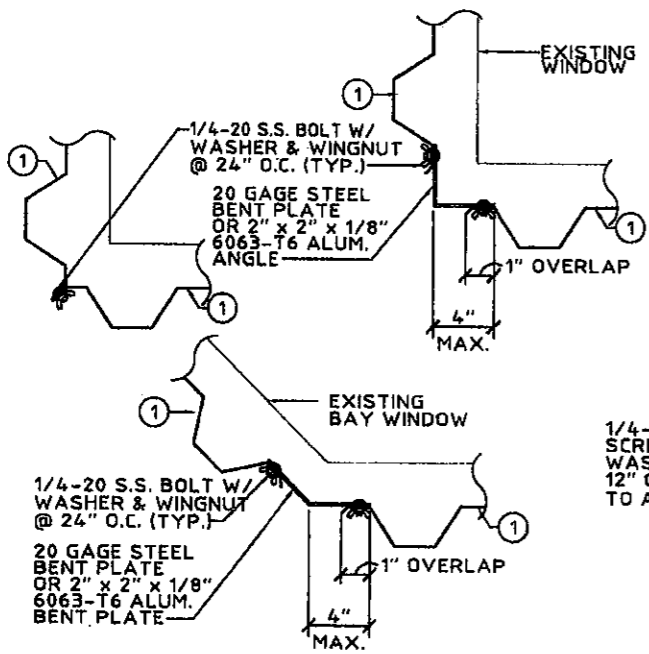

(R) TYPICAL CORNER CLOSURE DETAILS (PLAN)
SCALE: 1-1/2" = 1'-0"

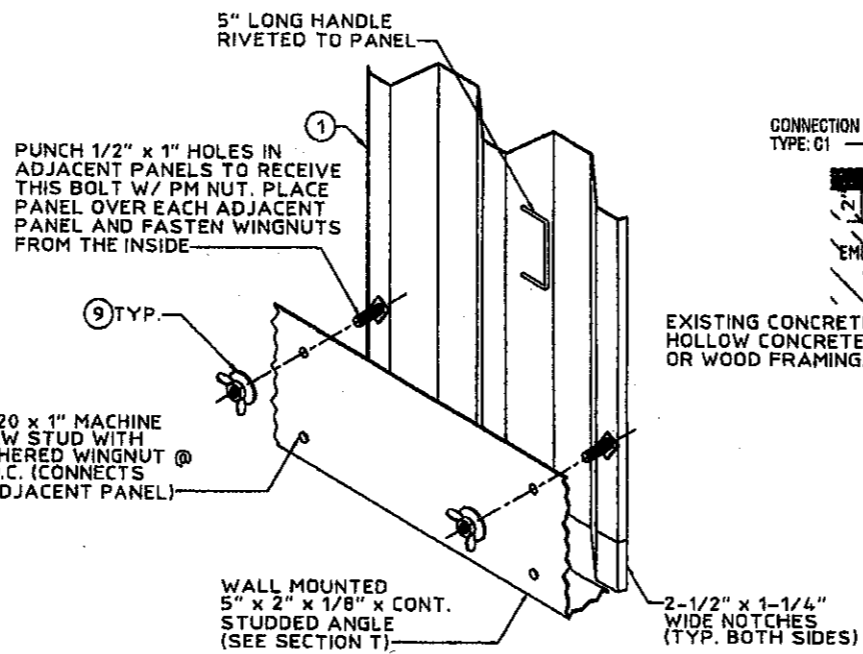

(S) OPTIONAL INTERIOR FASTENING DETAIL (ISOMETRIC)
N.T.S.

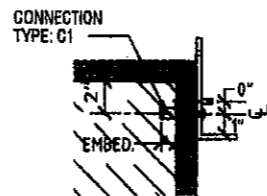

(T) INTERIOR FASTENING ANGLE ASSEMBLY
SCALE: 1-1/2" = 1'-0"

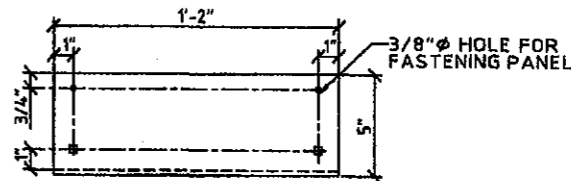

(MAX. PANEL HEIGHT = 7'-4" & MAX. DESIGN LOAD 72.00P.S.F.)

DETAILS (S) & (T) NOTE:
THESE DETAILS DEPICT THE CONNECTION OF THE LAST PANEL FOR AN OPENING WITH PANELS INSTALLED FROM INSIDE. USE OF THESE DETAILS SHALL BE IN CONJUNCTION WITH AN "H" HEADER OR "U" HEADER TOP MOUNT.

PRODUCT REVISED
as complying with the Florida Building Code
Acceptance No **09-0114.04**
Expiration Date **07/19/2011**
By *Helmut A. Miller*
Miami Dade Product Control Division

PRODUCT RENEWED
as complying with the Florida Building Code
Acceptance No **11-0428.04**
Expiration Date **07/19/2016**
By *Helmut A. Miller*
Miami Dade Product Control



KNEZEVICH ASSOCIATES
Consulting Engineers
2590 S.W. 105th Terrace, Davie, Florida 33324
(954) 821-8933 • F (954) 452-7860 • COA 27688
www.knezevich.com email: info@knezevich.com

Town & Country INDUSTRIES
Wholesale Aluminum and Building Products
400 West McKee Road, Fort Lauderdale, FL 33309
Phone 954.970.9999 FAX 954.970.9988

no.	date	by	description

V.J. Knezevich
Professional Engineer
FL License No.: PE 0010663
FLORIDA COA 19: 27688

[Signature]
Sept 3, 2008
drawn by *[Signature]*
date 09/01/2008
project no. **08-352**

0.0615" ALUMINUM STORM PANEL

ANCHOR SCHEDULE
FASTENER MAXIMUM SPACING (INCHES) REQUIRED FOR VARIOUS DESIGN LOADS AND SPANS

EXST. STRUC.	ANCHOR TYPE	LOAD (W) P.S.F. MAX. (SEE NOTE 1)	SPANS UP TO 6'-0" (SEE NOTE 1)		SPANS UP TO 8'-8" (SEE NOTE 1)		SPANS UP TO 12'-0" (SEE NOTE 1)		SPANS UP TO 6'-0" (SEE NOTE 1)		SPANS UP TO 8'-8" (SEE NOTE 1)		SPANS UP TO 12'-0" (SEE NOTE 1)													
			MIN. 1" EDGE DISTANCE						MIN. 2 1/2" EDGE DISTANCE																	
			CONNECTION TYPE (SEE NOTE 3)			CONNECTION TYPE (SEE NOTE 3)			CONNECTION TYPE (SEE NOTE 3)			CONNECTION TYPE (SEE NOTE 3)			CONNECTION TYPE (SEE NOTE 3)											
			C1	C2	C3	C4	C5	C1	C2	C3	C4	C5	C1	C2	C3	C4	C5	C1	C2	C3	C4	C5				
CONCRETE	1/4" ITW TAPCON W/ 1-3/4" MIN. EMBEDMENT	43.0	14	14	14	14	8	14	14	14	14	5	14	11	14	14	4	14	14	14	14	14	14	14	14	9
		50.0	14	14	14	14	6	14	14	14	14	4	14	8	14	14	3	14	14	14	14	14	10	14	14	7
		72.0	14	14	14	14	4	14	8	14	12	3	14	5	14	6	14	14	14	14	14	14	10	14	14	6
		84.0	14	11	14	14	4	14	6	14	7	14	5	14	6	14	14	14	13	14	14	14	9	14	14	6
	150.0	14	5	14	6	14	5	14	6	14	5	14	6	14	6	14	6	14	6	14	6	14	6	14	6	
	ELCO ULTRACON WITH 1/4" W/ 1-3/4" MIN. EMBEDMENT	43.0	14	14	14	14	12	14	14	14	8	14	10	14	14	6	14	14	14	14	14	14	12	14	14	8
		50.0	14	14	14	14	10	14	14	14	7	14	7	14	13	5	14	14	14	14	14	14	10	14	14	7
		72.0	14	14	14	14	7	14	7	14	11	5	14	5	13	5	4	14	14	14	14	14	10	14	14	7
		84.0	14	10	14	14	6	14	5	14	6	4	14	5	13	5	4	14	11	14	14	14	10	14	14	5
	150.0	14	5	13	5	4	14	5	13	5	4	14	5	13	5	4	14	5	13	5	5	14	5	13	5	
	HOLLOW CONCRETE BLOCK	1/4" ALL POINTS SOLID-SET ANCHOR WITH 7/8" EMBEDMENT & 1/4"-20 STAINLESS STEEL MACHINE SCREW	43.0	14	14	14	14	9	14	14	14	6	14	7	14	14	4	14	14	14	14	14	14	14	14	10
			50.0	14	14	14	14	8	14	10	14	14	5	13	5	13	9	4	14	14	14	14	14	14	14	10
72.0			14	10	14	14	5	12	5	12	7	3	10	3	9	3	3	14	14	14	14	14	14	14	14	6
84.0			14	7	14	14	4	10	4	10	4	3	10	3	9	3	3	14	12	14	14	14	14	14	14	6
150.0		10	3	9	3	3	10	3	9	3	3	14	6	14	6	6	14	6	14	6	6	14	6	14	6	
1/4" ELCO MALE/ FEMALE PANELMATE W/ 1-7/8" MIN. EMBED. & 1/4"-20 MACHINE SCREW WITH NUT		43.0	12	12	12	12	12	12	12	12	10	12	9	12	12	7	12	12	12	12	12	12	12	12	12	9
		50.0	12	12	12	12	12	12	12	12	8	12	7	12	12	6	12	12	12	12	12	12	12	12	12	7
		72.0	12	12	12	12	8	12	6	12	10	5	12	4	12	5	4	12	12	12	12	12	10	12	12	6
		84.0	12	10	12	12	7	12	5	12	6	5	12	4	12	5	4	12	12	12	12	12	10	12	12	6
150.0		12	4	12	5	4	12	4	12	5	4	12	4	12	5	4	12	6	12	6	5	12	6	12	6	
1/4" ELCO CRETE FLEX W/ 1-3/4" MIN. EMBEDMENT		43.0	14	14	14	14	14	14	14	14	14	14	14	14	14	14	14	14	14	14	14	14	14	14	14	12
		50.0	14	14	14	14	14	14	14	14	14	14	14	14	14	14	14	14	14	14	14	14	14	14	14	12
	72.0	14	14	14	14	14	14	14	14	14	14	14	14	14	14	14	14	14	14	14	14	14	14	14	12	
	84.0	14	14	14	14	14	14	14	14	14	14	14	14	14	14	14	14	14	14	14	14	14	14	14	12	
150.0	14	7	14	14	14	14	14	14	14	14	14	14	14	14	14	14	14	14	14	14	14	14	14	12		

ANCHOR SCHEDULE
FASTENER MAXIMUM SPACING (INCHES) REQUIRED FOR VARIOUS DESIGN LOADS AND SPANS

EXST. STRUC.	ANCHOR TYPE	LOAD (W) P.S.F. MAX. (SEE NOTE 1)	MIN. 3/4" EDGE DISTANCE													
			CONNECTION TYPE (SEE NOTE 3)													
			C1	C2	C3	C4	C5									
			WOOD	1/4" x 3" MIN. LONG LAG SCREW PARALLEL OR PERP. TO WOOD GRAIN	43.0	14	14	14	14	14	14	14	10	14	14	14
50.0	14	14			14	14	13	14	14	14	9	14	13	14	6	
72.0	14	14			14	14	9	14	12	14	14	6	14	8	9	5
84.0	14	14			14	14	7	14	9	14	11	5	14	8	14	9
150.0	14	8		14	9	5	14	8	14	9	5	14	8	14	9	5
7/16" WOOD BUSHING W/ 5/8" MIN. EMBED. & 1/4"-20 STAINLESS STEEL MACHINE SCREW	43.0	14		14	14	14	13	14	14	14	14	9	14	10	14	6
	50.0	14		14	14	14	11	6	11	11	11	8	3	8	5	
	72.0	11		6	11	11	7	3	7	4	6	6	5	5		
	84.0	9		4	9	9	6	6	6	6	6	6	5	5		
150.0	6	5		5	5	6	5	6	5	6	5	6	5			
1/4" ELCO MALE/ FEMALE PANELMATE W/ 1-7/8" MIN. EMBED. & 1/4"-20 MACHINE SCREW WITH NUT	43.0	14		14	14	14	13	14	14	14	14	9	14	10	14	6
	50.0	14		14	14	14	11	14	14	14	8	14	7	14	13	5
	72.0	14	14	14	14	8	14	11	5	14	5	13	5	4		
	84.0	14	10	14	14	6	14	5	14	6	4	14	5	13	5	4
150.0	14	5	13	5	4	14	5	13	5	4	14	5	13	5	4	

- ANCHOR NOTES:**
- SPANS AND LOADS SHOWN HERE ARE FOR DETERMINING ANCHOR SPACING ONLY. ALLOWABLE STORM PANEL SPANS FOR SPECIFIC LOADS MUST BE LIMITED TO THOSE SHOWN IN TABLE.
 - ENTER ANCHOR SCHEDULE BASED ON THE EXISTING STRUCTURE MATERIAL, ANCHOR TYPE AND EDGE DISTANCE. SELECT DESIGN LOAD GREATER THAN OR EQUAL TO NEGATIVE DESIGN LOAD ON SHUTTER AND SELECT SPAN GREATER THAN OR EQUAL TO SHUTTER SPAN.
 - SEE MOUNTING SECTION DETAILS FOR IDENTIFICATION OF CONNECTION TYPE.
 - EXISTING STRUCTURE MAY BE CONCRETE, HOLLOW CONCRETE BLOCK OR WOOD FRAMING. REFERENCE ANCHOR SCHEDULE FOR PROPER ANCHOR TYPE BASED ON TYPE OF EXISTING STRUCTURE.
 - ANCHORS SHALL BE INSTALLED IN ACCORDANCE WITH MANUFACTURERS' RECOMMENDATIONS.
 - MINIMUM EMBEDMENT AND EDGE DISTANCE EXCLUDES WALL FINISH OR STUCCO.
 - WHERE EXISTING STRUCTURE IS WOOD FRAMING, WOOD FRAMING CONDITIONS VARY. FIELD VERIFY THAT FASTENERS ARE INTO ADEQUATE WOOD FRAMING MEMBERS, NOT PLYWOOD. FASTENING TO PLYWOOD IS ACCEPTABLE ONLY FOR SIDE CLOSURE PIECES.
 - WHERE LAG SCREWS FASTEN TO NARROW FACE OF STUD FRAMING, FASTENER SHALL BE LOCATED IN CENTER OF NOMINAL 2" x 4" (MIN.) WOOD STUD. 3/4" EDGE DISTANCE IS ACCEPTABLE FOR WOOD FRAMING. WOOD STUD SHALL BE "SOUTHERN PINE" G=0.55 OR GREATER DENSITY. LAG SCREWS SHALL HAVE PHILLIPS PAN HEAD OR HEX HEAD.
 - MACHINE SCREWS SHALL HAVE MINIMUM OF 1/2" ENGAGEMENT OF THREADS IN BASE ANCHOR AND MAY HAVE EITHER A PAN HEAD, TRUSS HEAD, OR WAFER HEAD (SIDEWALK BOLT), U.O.N.
 - DESIGNATES ANCHOR CONDITIONS WHICH ARE NOT ACCEPTABLE USES.
 - * DESIGNATES ANCHORS WHICH ARE REMOVABLE BY REMOVING MACHINE SCREW, NUT OR WASHERED WINGNUT.
 - ALL POINTS SOLID SET AND POWERS CALK-IN ANCHORS MAY ONLY BE USED IN CONCRETE WALLS, HOLLOW CONCRETE BLOCK WALLS OR CONCRETE SLABS ON GRADE.
 - FOR ELCO CRETEFLEX SS4, CONCRETE STRENGTH, Fc=3.5 KSI. FOR ITW TAPCON, CONCRETE STRENGTH, Fc=3.2 KSI. FOR ALL OTHERS CONCRETE STRENGTH, Fc= 3 KSI.

PRODUCT RENEWED
as complying with the Florida
Building Code
Acceptance No 11-0428.04
Expiration Date 07/19/2016
By *Helmut A. Miller*
Miami Dade Product Control

Ka
KNEZEVICH ASSOCIATES
Consulting Engineers
2500 S.W. 103rd Ave., Suite 33304
(954) 881-9833 • Fax (954) 881-9837
www.knezovich.com • email: vknezovich@knezovich.com

Town & Country INDUSTRIES
Wholesale Aluminum and Building Products
400 West McVay Road
Fort Lauderdale, FL 33309
Phone 954-970-9999 Fax 954-970-9988

no.	description	by	date

V.J. Knezovich
Professional Engineer
FL License No: PE 0010603
Florida CE# 1037 27000

Sept 3, 2008
date 09/01/2008
project no. 08-352

